

## Master Flash® Residential

### 1.1 Master Flash® Residential – Technical Data Sheet

- Master Flash® Residential is made of EPDM rubber (ethylene propylene diene monomer) or silicone rubber.
- It is specifically designed for sloped roofs up to 45° covered various roofing materials, such as ceramic, concrete tiles or roof shingles.
- The base of the flashing made out of bonded aluminium allows easy shaping to fit the roofing material geometry.
- Roof flashings are intended for watertight sealing around installation elements / ducts penetrating the roof slope (i.e. ventilation pipes, solar ducts, chimney flues, electric cables and wires or other elements passing through the roof slope).

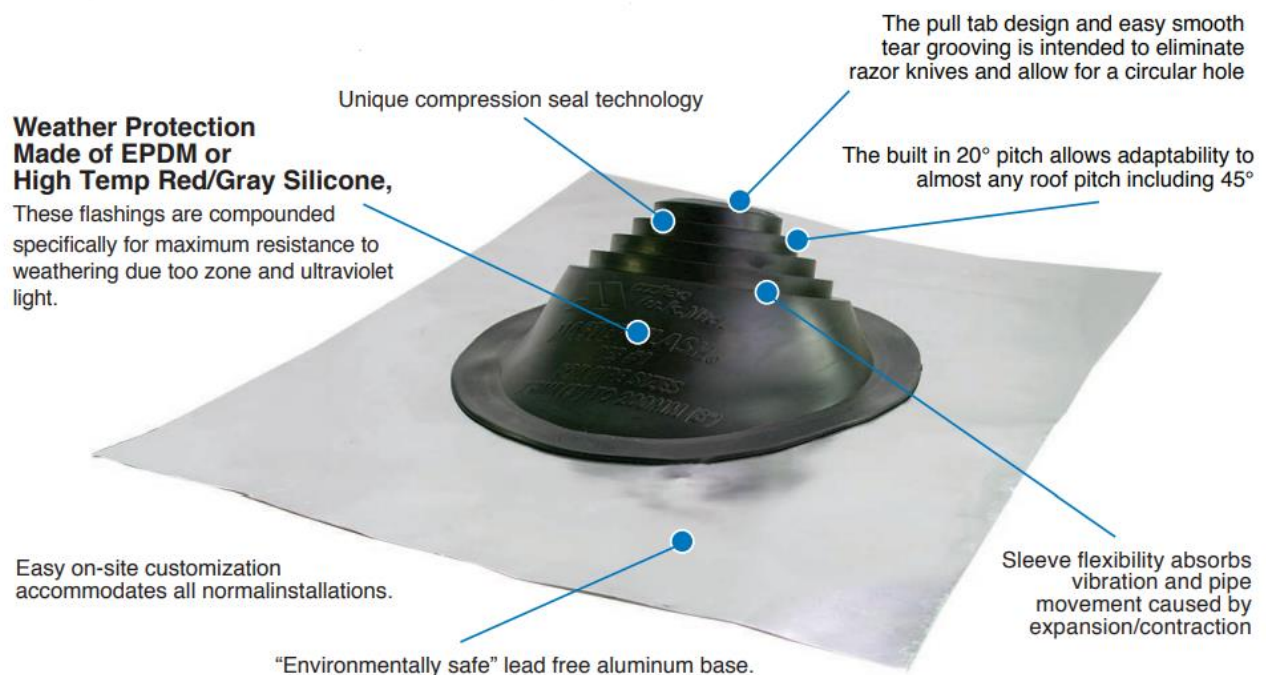

## 1.2 Master Flash® Residential – Material Specification and Sizes

Master Flash®	EPDM 500	Silicone
ADVANCED OZONE RESISTANCE tested to:	70 h @ 500 pphm	70 h @ 500 pphm
HIGH TEMPERATURE RESISTANCE		
tested to: intermittent	+135°C (+275°F)	+260°C (+500°F)
continuous	+100°C (+212°F)	+225°C (+437°F)
LOW TEMPERATURE RESISTANCE tested to:	-55°C (-67°F)	-74°C (-101°F)
TENSILE SET maximum	10 MPa (1450 psi)	5 MPa (725 psi)
COMPRESSION SET maximum	25%	50%



**RED SILICONE MASTER FLASH® RESIDENTIAL**



**BLACK EPDM MASTER FLASH® RESIDENTIAL**



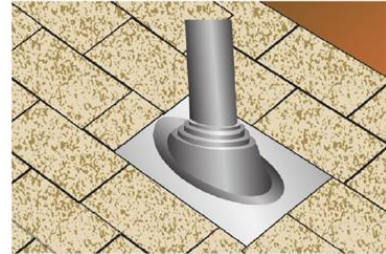
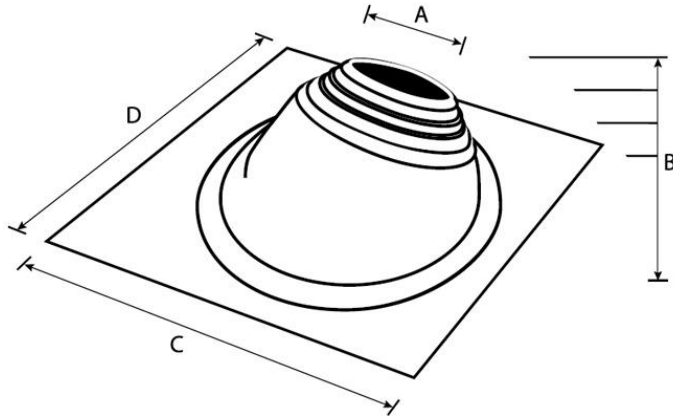

Master Flash® Residential Aluminium

No.	Pipe Range	Material	Black EPDM Catalogue Number	A-Top Opening Diameter	B x C-Aluminium Base Dimensions
Mini	Closed - 3 - 1/4" (0 - 82 mm)	Black or Grey EPDM, Silicone	RS051BA	Closed	16" x 19 - 1/4" (410 x 490 mm)
1	2 - 3/4" - 8" (69 - 203 mm)	Black or Grey EPDM, Silicone	RS101BA	2 - 3/4" (69 mm)	20" x 24" (508 x 609 mm)
1.5	6" - 8" (150 - 203 mm)	Black or Grey EPDM, Silicone	RS151XX	6" (150 mm)	19" x 24" (483 x 609 mm)
2	7" - 11 - 1/2" (177 - 292 mm)	Black or Grey EPDM, Silicone	RS201BA	7" (177 mm)	26" x 30" (660 x 762 mm)
3	11" - 18 - 1/2" (279 - 469 mm)	Black or Grey EPDM, Silicone	RS301BA	11" (279 mm)	35" x 35" (889 x 889 mm)

## COMPOUND AND SPECIFICATION DATA FOR MASTER FLASH® BLACK EPDM

TYPICAL PHYSICAL PROPERTIES OF MF EPDM  
 ASTM D2000 M3BA510 A14, B13, C12, F17, Z1, Z2, Z3, Z4, Z5.

PROPERTY		VALUE	TEST METHOD
BASE MATERIAL		CROSS LINKED EPDM ETHYLENE PROPYLENE DIENE TERPOLYMER	N/A
COLOR		BLACK	N/A
TEST LEVEL		3	GRADE
TEST TEMPERATURE		B 100° C	GRADE
VOLUME SWELL		NO REQUIREMENT	CLASS
DUROMETER		50 (SHORE)	ASTM D 2240
TENSILE STRENGTH		10 MPA (1450 psi) MINIMUM	ASTM D 412
A14	HEAT AGING	70 hrs. @ 100° C Change in hardness Max +10 pts Change in tensile Max -25 % Change in ultimate elong. Max -25%	ASTM D 573
B13	COMPRESSION SET	22 hrs. @ 70 ° C MAX 25 %	ASTM D 395 B
C12	OZONE RESISTANCE	70 hrs. @ 50 pphm	ASTM D 1171
F17	LOW TEMPERATURE BRITTLINESS	3 MINUTES @ -40° C PASS	ASTM D 2137A, 9.3.2
Z1	TARGET HARDNESS	55 +/-5 SHORE A	ASTM 2240
Z2	SPECIFIC RUBBER	EPDM	PASS
Z3	HORIZONTAL FLAME RESISTANCE	NOT TO EXCEED 3 IN/ MINUTE	ASTM 2240

## COMPOUND AND SPECIFICATION DATA FOR MASTER FLASH® SILICONE

TYPICAL PHYSICAL PROPERTIES OF MF SILICONE  
 ASTM D2000 M4 GE 505 A19, B37, C12, F19, Z1, Z2, Z3, Z4, Z5, Z6, Z7.

PROPERTY		VALUE	TEST METHOD
BASE MATERIAL		SILICONE	N/A
COLOR		TERRA COTTA/GRAY	N/A
TEST LEVEL		4	GRADE
TEST TEMPERATURE		225° C	GRADE
VOLUME SWELL		MAX 80%	CLASS
DUROMETER		50 (SHORE)	ASTM D 2240
TENSILE STRENGTH		5 MPA (725 psi) MINIMUM	ASTM D 412
ULTIMATE ELONGATION		250 % MINIMUM	ASTM 412
A19	HEAT AGING	70 hrs. @ 225 C Change in hardness Max +10 pts Change in tensile Max -25 % Change in ultimate elong. Max -30%	ASTM D 573
B37	COMPRESSION SET	22 hrs. @ 175° C MAX 25%	ASTM D 395 B
C12	OZONE RESISTANCE	70 hrs. @ 50 pphm 38° C 100% quality retention	ASTM D 1171
F19	LOW TEMPERATURE BRITTLENESS	3 MINUTES @ -55° C (-67° F)	ASTM D 2137A, 9.3.2
Z1	TARGET HARDNESS	55 SHORE A	ASTM 2240
Z2	SPECIFIC RUBBER	SILICONE	N/A
Z3	HORIZONTAL FLAME RESISTANCE	NOT TO EXCEED 3 IN/ MINUTE	UL-94